

# TS-QS8LL314H40PC

## 400G-ER8 QSFP-DD Transceiver

### Features:

- Compliant with IEEE std 802.3cnTM-2019:
- 400GBASE-ER8 optical interface
- 400GAUI-8 electrical interface
- Compliant with QSFP-DD MSA HW Rev 5.0 with duplex LC connector
- Compliant with QSFP-DD CMIS Rev 4.0
- Case operating temperature 0°C to 70°C
- Two wire serial Interface with digital diagnostic monitoring
- Complies with EU Directive 2011/65/EU (RoHS compliant)
- Class 1/1M Laser

### Module Characteristics

**Table 1 – Absolute Maximum Ratings**

Parameter	Symbol	Min.	Max.	Unit	Notes
Storage Temperature	TS	-40	85	°C	
Supply Voltage	VCC	-0.5	3.6	V	
Relative Humidity (non-condensing)	RH	5	95	%	
Data Input Voltage Differential	IVDIP-VDINI	-	1	V	
Control Input Voltage	VI	-0.3	VCC+0.5	V	
Control Output Current	IO	-20	20	mA	

**Table 2 – Recommended Operating Conditions**

Parameter	Symbol	Min.	Typical	Max.	Unit	Notes
Operating Case Temperature	TOPR	0	-	70	°C	
Power Supply Voltage	VCC	3.135	3.3	3.465	V	
Instantaneous peak current at hot plug	ICC_IP	-	-	5200	mA	
Sustained peak current at hot plug	ICC_SP	-	-	4290	mA	
Maximum Power Dissipation	PD	-	-	13	W	
Maximum Power Dissipation, Low Power Mode	PDLP	-	-	1.5	W	
Signalling Speed per Lane	DRL	-	26.5625	-	GBd	

Control Input Voltage High	V <sub>IH</sub>	VCC*0.7	-	VCC+0.3	V	
Control Input Voltage Low	V <sub>IL</sub>	-0.3	-	VCC*0.3	V	
Two Wire Serial Interface Clock Rate	-	-	-	400	kHz	
Power Supply Noise	-	-	-	66	mVpp	
Rx Differential Data Output Load	-	-	100	-	Ohm	
Operating Distance	-	0.002	-	40(30)	km	1

Note 1: Channel insertion loss is 18dB for 40km and 15dB for 30km.

## Functional Characteristics (Optical)

The following tables list the performance specifications for the various functional blocks of the integrated optical transceiver module.

**Table 3 – Transmitter Optical Specifications**

Parameter	Symbol	Min.	Typical	Max.	Unit	Notes
Wavelength L0	$\lambda C0$	1272.55	1273.55	1274.54	nm	
Wavelength L1	$\lambda C1$	1276.89	1277.89	1278.89	nm	
Wavelength L2	$\lambda C2$	1281.25	1282.26	1283.27	nm	
Wavelength L3	$\lambda C3$	1285.65	1286.67	1287.68	nm	
Wavelength L4	$\lambda C4$	1294.53	1295.56	1296.59	nm	
Wavelength L5	$\lambda C5$	1299.02	1300.06	1301.09	nm	
Wavelength L6	$\lambda C6$	1303.54	1304.59	1305.63	nm	
Wavelength L7	$\lambda C7$	1308.09	1309.14	1310.19	nm	
Side Mode Suppression Ratio	SMSR	30	-	-	dB	
Total Average Launch Power	AOPT	-	-	14.6	dBm	
Average Launch Power, each lane	AOPL	-0.6	-	5.6	dBm	1
Outer Optical Modulation Amplitude (OMA <sub>outer</sub> ), each Lane, 40km	TOMA	2.4	-	6.4	dBm	
Outer Optical Modulation Amplitude (OMA <sub>outer</sub> ), each Lane, 30km	TOMA	0.4	-	4.4	dBm	
Difference in Launch Power between any two Lanes (OMA <sub>outer</sub> )	DT_OMA	-	-	4	dB	
Launch Power in OMA <sub>outer</sub> minus TDECQ, each lane, 40km	TOMA-TDECQ	1	-	-	dBm	
Launch Power in OMA <sub>outer</sub> minus TDECQ, each lane, 30km	TOMA-TDECQ	-1	-	-	dBm	
Transmitter and Dispersion Eye Closure for PAM4 (TDECQ), each lane	TDECQ	-	-	3.4	dB	

Average Launch Power of OFF Transmitter, each lane	TOFF	-	-	-30	dBm	
Extinction Ratio	ER	6	-	-	dB	
RIN15OMA	RIN	-	-	-132	dB/Hz	
Optical Return Loss Tolerance	ORL	-	-	15	dB	
Transmitter Reflectance	TR	-	-	-26	dB	2

Note 1: Average launch power, each lane (min) is informative and not the principal indicator of signal strength

Note 2: Transmitter reflectance is defined looking into the transmitter

**Table 4 – Receiver Optical Specifications**

Parameter	Symbol	Min.	Typical	Max.	Unit	Notes
Wavelength L0	$\lambda C0$	1272.55	1273.55	1274.54	nm	
Wavelength L1	$\lambda C1$	1276.89	1277.89	1278.89	nm	
Wavelength L2	$\lambda C2$	1281.25	1282.26	1283.27	nm	
Wavelength L3	$\lambda C3$	1285.65	1286.67	1287.68	nm	
Wavelength L4	$\lambda C4$	1294.53	1295.56	1296.59	nm	
Wavelength L5	$\lambda C5$	1299.02	1300.06	1301.09	nm	
Wavelength L6	$\lambda C6$	1303.54	1304.59	1305.63	nm	
Wavelength L7	$\lambda C7$	1308.09	1309.14	1310.19	nm	
Damage Threshold, each Lane	AOPD	-3.4	-	-	dBm	
Average Receive Power, each Lane	AOPR	-18.6	-	-4.4	dBm	
Receive Power (OMAouter), each Lane	OMAR	-	-	-3.6	dBm	
Difference in Receive Power between any two Lanes (OMAouter)	DR_OMA	-	-	5.8	dB	
Receiver Reflectance	RR	-	-	-26	dB	
Receiver Sensitivity (OMAouter), each Lane, 40km	SOMA	-	-	-16.1	dBm	1
Receiver Sensitivity (OMAouter), each Lane, 30km	SOMA	-	-	-15.1	dBm	1
Stressed Receiver Sensitivity (OMAouter), each Lane, 40km	SRS	-	-	-14.1	dBm	2
Stressed Receiver Sensitivity (OMAouter), each Lane, 30km	SRS	-	-	-13.1	dBm	2

Note 1: Receiver sensitivity (OMAouter), each lane (max) is informative and is defined for a transmitter with SECQ of 1.4 dB.

Note 2: Measured with conformance test signal at TP3 for the BER = 2.4x10<sup>-4</sup>

## Functional Characteristics (Electrical)

**Table 5 – Electrical Specification High Speed Signal (compliant with IEEE 802.3 400GAUI-8)**

<b>Receiver (Module Output)</b>						
<b>Parameter</b>	<b>Symbol</b>	<b>Min.</b>	<b>Typical</b>	<b>Max.</b>	<b>Unit</b>	<b>Notes</b>
AC common-mode output Voltage (RMS)		-	-	17.5	mV	
Differential output Voltage		-	-	900	mV	
Near-end Eye height, differential		70	-	-	UI	
Far-end Eye height, differential		30	-	-	UI	
Far end pre-cursor ratio		-	-	2.5	%	
Differential Termination Mismatch		-	-	10	%	
Transition Time (min, 20% to 80%)		9.5	-	-	ps	
DC common mode Voltage		-350	-	2850	mV	
<b>Transmitter (Module Input)</b>						
<b>Parameter</b>	<b>Symbol</b>	<b>Min.</b>	<b>Typical</b>	<b>Max.</b>	<b>Unit</b>	<b>Notes</b>
Differential pk-pk input Voltage tolerance		900	-	-	mV	
Differential termination mismatch		-	-	10	%	
Single-ended voltage tolerance range		-0.4	-	3.3	V	
DC common mode Voltage		-350	-	2850	mV	

**Table 6 – Electrical Specification Low Speed Signal (compliant with QSFP-DD HW Rev 5.0)**

<b>Parameter</b>	<b>Symbol</b>	<b>Min.</b>	<b>Max.</b>	<b>Unit</b>	<b>Condition</b>
Module output SCL and SDA	VOL	0	0.4	V	
	VIL	-0.3	VCC*0.3	V	
Module Input SCL and SDA	VIH	VCC*0.7	VCC+0.5	V	
	VIL	-0.3	0.8	V	
InitMode, ResetL and ModSelL	VIH	2	VCC+0.3	V	
	VOL	0	0.4	V	
IntL	VOH	VCC-0.5	VCC+0.3	V	

## Pin Definitions

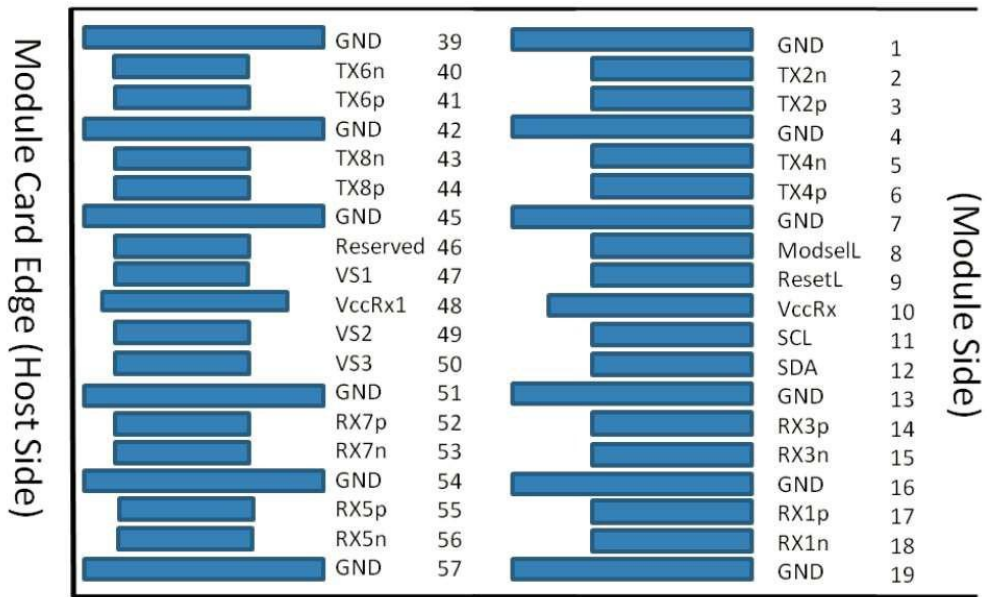

Bottom side viewed from bottom

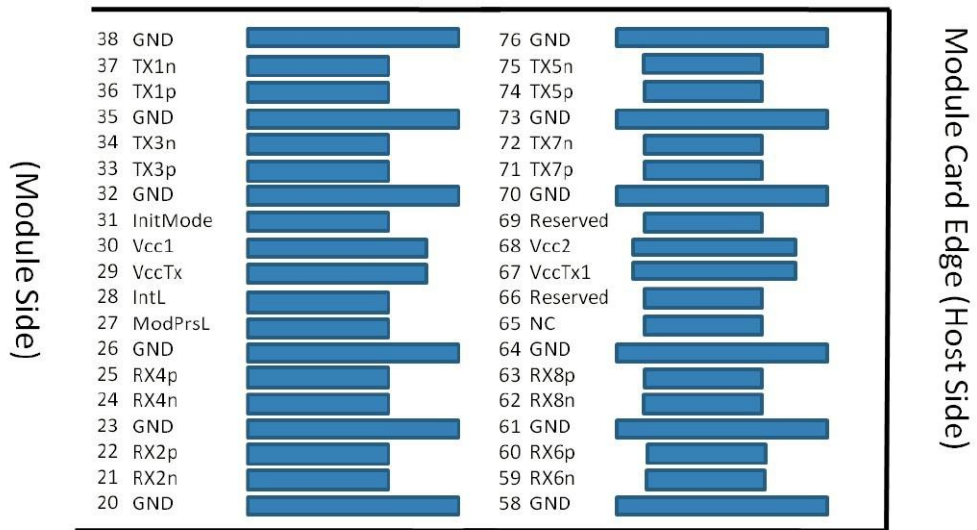

Top side viewed from top

Figure 1 – Pin definitions of the module high speed inputs/outputs

**Table 7 – Module Pin Definitions**

Pin #	Logic	Symbol	Definition	Pin #	Logic	Symbol	Definition
1		GND	Ground	39		GND	Ground
2	CML-I	Tx2n	Transmitter Inverted Data Input	40	CML-I	Tx6n	Transmitter Inverted Data Input
3	CML-I	Tx2p	Transmitter Non-inverted Data Input	41	CML-I	Tx6p	Transmitter Non-inverted Data Input
4		GND	Ground	42		GND	Ground
5	CML-I	Tx4n	Transmitter Inverted Data Input	43	CML-I	Tx8n	Transmitter Inverted Data Input
6	CML-I	Tx4p	Transmitter Non-inverted Data Input	44	CML-I	Tx8p	Transmitter Non-inverted Data Input
7		GND	Ground	45		GND	Ground
8	LVTTL-I	ModSelL	Module Select	46		Reserved	
9	LVTTL-I	ResetL	Module Reset	47		VS1	Module Vendor Specific 1
10		VccRx	+3.3V Power Supply Receiver	48		VccRx1	3.3V Power Supply
11	LVCMS-I/O	SCL	2-wire serial interface clock	49		VS2	Module Vendor Specific 2
12	LVCMS-I/O	SDA	2-wire serial interface data	50		VS3	Module Vendor Specific 3
13		GND	Ground	51		GND	Ground
14	CML-O	Rx3p	Receiver Non-inverted Data Output	52	CML-O	Rx7p	Receiver Non-inverted Data Output
15	CML-O	Rx3n	Receiver Inverted Data Output	53	CML-O	Rx7n	Receiver Inverted Data Output
16		GND	Ground	54		GND	Ground
17	CML-O	Rx1p	Receiver Non-inverted Data Output	55	CML-O	Rx5p	Receiver Non-inverted Data Output
18	CML-O	Rx1n	Receiver Inverted Data Output	56	CML-O	Rx5n	Receiver Inverted Data Output
19		GND	Ground	57		GND	Ground
20		GND	Ground	58		GND	Ground
21	CML-O	Rx2n	Receiver Inverted Data Output	59	CML-O	Rx6n	Receiver Inverted Data Output
22	CML-O	Rx2p	Receiver Non-inverted Data Output	60	CML-O	Rx6p	Receiver Non-inverted Data Output
23		GND	Ground	61		GND	Ground
24	CML-O	Rx4n	Receiver Inverted Data Output	62	CML-O	Rx8n	Receiver Inverted Data Output
25	CML-O	Rx4p	Receiver Non-inverted Data Output	63	CML-O	Rx8p	Receiver Non-inverted Data Output
26		GND	Ground	64		GND	Ground
27	LVTTL-O	ModPrsL	Module Present	65		NC	Not connected
28	LVTTL-O	IntL	Interrupt	66		Reserved	
29		VccTx	+3.3V Power Supply	67		VccTx1	3.3V Power Supply

		Transmitter					
30		Vcc1	+3.3V Power Supply	68	Vcc2	3.3V Power Supply	
31	LVTTL-I	InitMode	Initialization mode	69	Reserved		
32		GND	Ground	70	GND	Ground	
33	CML-I	Tx3p	Transmitter Non-inverted Data Input	71	CML-I	Tx7p	Transmitter Non-inverted Data Input
34	CML-I	Tx3n	Transmitter Inverted Data Input	72	CML-I	Tx7n	Transmitter Inverted Data Input
35		GND	Ground	73	GND	Ground	
36	CML-I	Tx1p	Transmitter Non-inverted Data Input	74	CML-I	Tx5p	Transmitter Non-inverted Data Input
37	CML-I	Tx1n	Transmitter Inverted Data Input	75	CML-I	Tx5n	Transmitter Inverted Data Input
38		GND	Ground	76	GND	Ground	

### Recommended QSFP-DD Host Board Schematic

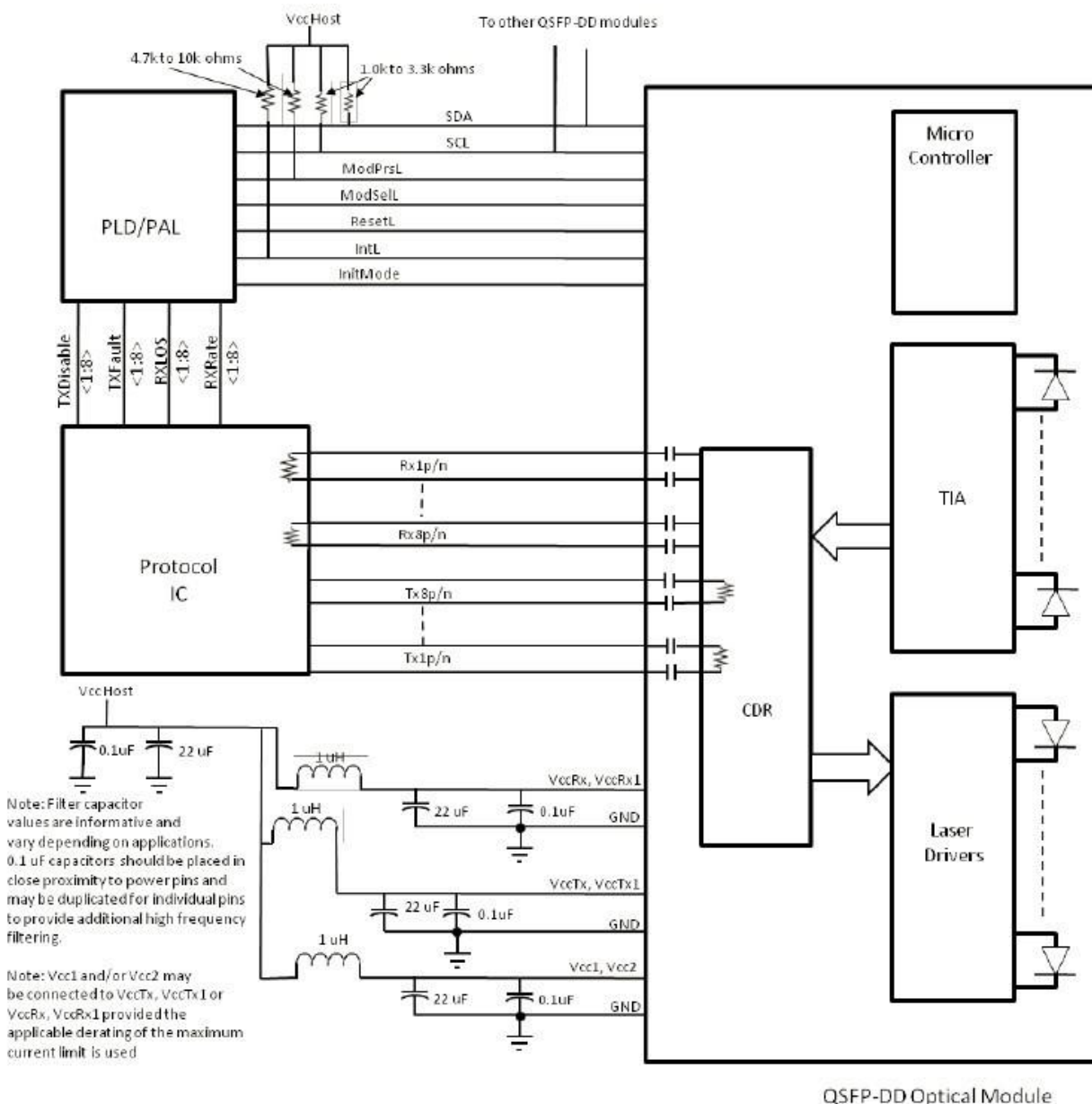

Figure 2 – Recommended QSFP-DD Host Board Schematic

**Table 8 – Timing for Soft Control and Status Functions**

Parameter	Symbol	Min.	Max.	Unit	Notes
MgmtInit Duration		-	2000	ms	
ResetL Assert Time	t_reset_init	10	-	μs	
IntL Assert Time	ton_IntL	-	200	ms	
IntL Deassert Time	toff_IntL	-	500	μs	
Rx LOS Assert Time (fast mode)	ton_losf	-	1	ms	
Rx LOS Deassert Time (fast mode)	toff_losf	-	3	ms	
Tx Fault Assert Time	ton_Txfault	-	200	ms	
Flag Assert Time	ton_flag	-	200	ms	
Mask Assert Time	ton_mask	-	100	ms	
Mask Deassert Time	toff_mask	-	100	ms	
Module Select Wait Time	ModSelL Wait Time	-	N/A		Note

Note: This feature is not supported

**Table 9 – I/O Timing for Squelch and Disable**

Parameter	Symbol	Min.	Max.	Unit	Notes
Rx Squelch Assert Time	ton_Rxsq	-	15	ms	
Rx Squelch Deassert Time	toff_Rxsq	-	1500	ms	
Tx Squelch Assert Time	ton_Txsq	-	400	ms	
Tx Squelch Deassert Time	toff_Txsq	-	1500	ms	Based on modulation
Tx Disable Assert Time (fast mode)	ton_Txdisf	-	3	ms	
Tx Disable Deassert Time (fast mode)	toff_Txdisf	-	10	ms	
Rx Output Disable Assert Time	ton_Rxdis	-	100	ms	
Rx Output Disable Deassert Time	toff_Rxdis	-	100	ms	
Squelch Disable Assert Time	ton_sqdis	-	N/A	ms	Not support
Squelch Disable Deassert Time	toff_sqdis	-	N/A	ms	Not support

**Table 10 – Digital Diagnostics**

Parameter	Range	Accuracy	Unit	Calibration
Temperature	0 to 70	±3	°C	Internal
Voltage	0 to VCC	0.1	V	Internal
Tx Bias Current (Each Lane)	0 to 100	10%	mA	Internal
Tx Output Power (Each Lane)	-0.6 to +5.6	±3	dB	Internal
Rx Receive Power (Each Lane)	-18.6 to -4.4	±3	dB	Internal

## Mechanical Diagram



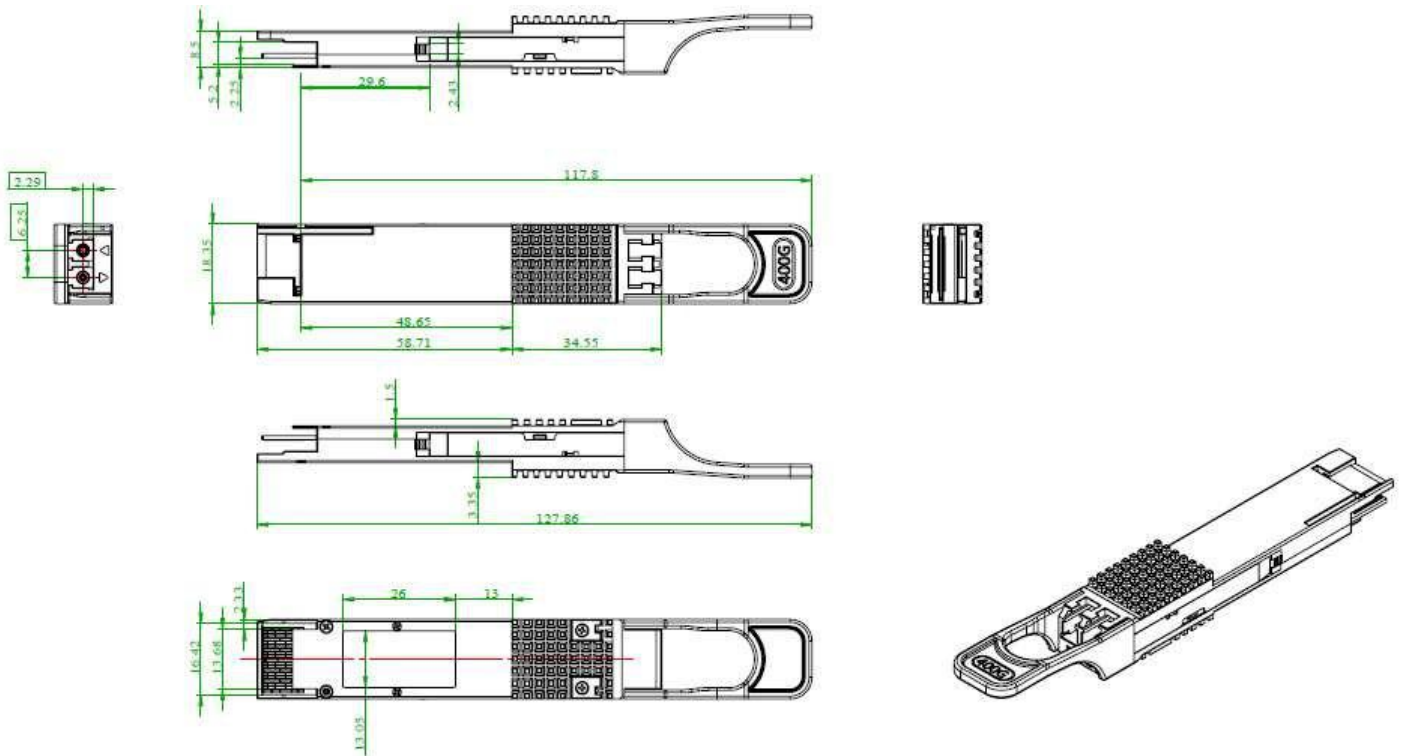

## Ordering Information

Table 11 - Ordering Information

Part No.	Application	Data Rate	Laser Source	Distance
TS-S8LL314H40PC	400GBASE-ER8	400GB Ethernet	EML	40km
TS-S8LL314H30PC	400GBASE-ER8L	400GB Ethernet	EML	30km

## Warnings

Handling Precautions: This device is susceptible to damage as a result of electrostatic discharge (ESD). A static free environment is highly recommended. Follow guidelines according to proper ESD procedures.

Laser Safety: Radiation emitted by laser devices can be dangerous to human eyes. Avoid eye exposure to direct or indirect radiation.

## **Legal Notice**

### **IMPORTANT NOTICE!**

All information contained in this document is subject to change without notice, at Transcom's sole and absolute discretion. Transcom warrants performance of its products to current specifications only in accordance with the company's standard one-year warranty; however, specifications designated as "preliminary" are given to describe components only, and Transcom expressly disclaims any and all warranties for said products, including express, implied, and statutory warranties, warranties of merchantability, fitness for a particular purpose, and non-infringement of proprietary rights. Please refer to the company's Terms and Conditions of Sale for further warranty information.

Transcom assumes no liability for applications assistance, customer product design, software performance, or infringement of patents, services, or intellectual property described herein. No license, either express or implied, is granted under any patent right, copyright, or intellectual property right, and Transcom makes no representations or warranties that the product(s) described herein are free from patent, copyright, or intellectual property rights. Products described in this document are NOT intended for use in implantation or other life support applications where malfunction may result in injury or death to persons. Transcom customers using or selling products for use in such applications do so at their own risk and agree to fully defend and indemnify Transcom for any damages resulting from such use or sale.

All information contained in this document is subject to change without notice. The products described in this document are NOT intended for use in implantation or other life support applications where malfunction may result in injury or death to persons.

The information contained in this document does not affect or change Transcom product specifications or warranties. Nothing in this document shall operate as an express or implied license or indemnity under the intellectual property rights of Transcom or third parties. All information contained in this document was obtained in specific environments, and is presented as an illustration. The results obtained in other operating environments may vary.

THE INFORMATION CONTAINED IN THIS DOCUMENT IS PROVIDED ON AN "AS IS" BASIS. In no event will Transcom be liable for damages arising directly from any use of the information contained in this document.